



5252 East 36th Street North
Wichita, KS USA 67220-3205
TEL: 316-686-7361
FAX: 316-686-6746

GREAT PLAINS INDUSTRIES, INC.

"A Great Plains Ventures Subsidiary"

www.gpi.net

1-800-835-0113

P-120H and P-200H Plastic Utility Pump

Owner's Manual

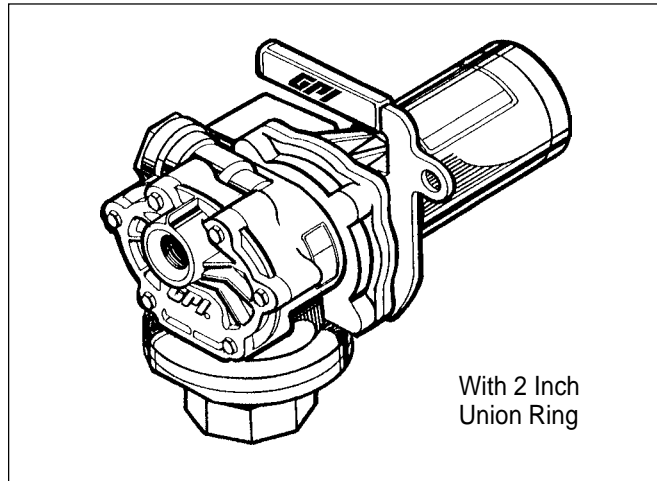

TABLE OF CONTENTS

General Information	1
Installation	2
Operation	2
Maintenance	4
Repair	5
Troubleshooting	8
Illustrated Parts List	9
Specifications	10
Parts and Service	11

GENERAL INFORMATION

Purpose of this Manual

This manual will assist you in operating and maintaining your pump. It provides information which will help you achieve years of dependable performance and trouble-free operation.

Using fluids, other than those for which the pump was designed, could lead to serious personal injury and void the warranty.

Before operating your pump, read this manual thoroughly. If you have problems with your pump, please refer to the Maintenance and Troubleshooting Sections.

For assistance, contact your dealer or the Customer Service Department.

How to Use this Manual

Specific part names and numbers are given in the Illustrated Parts List at the end of this manual.



This symbol is used throughout this manual to call your attention to safety messages.

Warnings alert you to the potential for personal injury.

Cautions call attention to practices or procedures which may damage your equipment.

Notes give you information that can improve efficiency of operations.

It is your responsibility to:

- make sure all operators have access to adequate instructions about safe operating and maintenance procedures.
- know and follow all safety precautions specified by your chemical manufacturer.
- know proper safety guidelines for providing electrical power to your pump.



Safety Instructions

For your safety, review the warnings and cautions below before operating your pump.

1. The system is approved for herbicides, pesticides, and other agricultural chemicals **only**. Do not use with gasoline, diesel, other flammable fluids, or micro-encapsulated chemicals.
2. When handling chemicals, always wear protective clothing such as goggles, gloves, and respirators, as instructed by the chemical manufacturer.
3. Serious electrical shock can result from operating electrical equipment on wet ground.
4. Inspect wiring regularly. Make sure the power cord is correctly attached to the battery. To avoid electrical shock, use extra care when connecting the pump to the battery.
5. Do not exceed standard duty cycle for non-viscous chemicals of 30 minutes ON and 30 minutes OFF. Allow the pump to cool for 30 minutes.

- Some chemical may spill from the pump during pump removal. Follow chemical label directions for cleanup and disposal.
- To avoid chemical exposure, follow chemical manufacturer's instructions for the disposal of contaminated water.
- Do not run the pump more than necessary without flow. "Dry running" can cause overheating and pump damage.
- To avoid personal injury, turn the pump OFF and disconnect from power before repair or service.
- For your protection, thoroughly flush the pump before cleaning or repairing.

Damage Inspection

Upon receipt, examine the pump and all parts for visible damage. If any items are damaged or missing, please contact your distributor.

INSTALLATION

Before pump installation, install the suction pipe and bung adapter on the tank. Used pumps must be flushed and cleaned before installation as outlined in the Maintenance Section.

To prevent leakage, seal all connecting threads with 3 to 4 turns of Teflon® tape during installation.

Install Suction Pipe

After sealing threads, tighten the suction pipe into the bottom of the bung adapter until only three threads are visible.

Install with 4-Inch Inlet

- Place the Teflon® gasket above the EPDM gasket. Center both between the bung adapter flange and threads.
- Tighten the bung adapter onto the tank, making sure the EPDM gasket stays centered. Torque to 50 ft. lbs. using a bung adapter wrench and a torque wrench.
- Make sure the bung adapter and pump inlet O-rings are well-seated.
- Place the pump on the bung adapter and press down firmly to seat the pump.
- Hold the pump in place and tighten the spin collar. Make sure the spin collar is not cross-threaded. (Figure 1)



Figure 1

- Torque the spin collar to 50 ft. lbs. Do not overtighten.

Install with 2-inch Union Ring Inlet

- Tighten the bung adapter onto the tank with a pipe wrench.
- Center the Teflon® gasket on the bung adapter.
- Position the pump on the bung adapter and gasket. (Figure 2)



Figure 2

- Hold the pump in place and tighten the union ring securely. Do not overtighten. Make sure the union ring is not cross-threaded. (Figure 3)



Figure 3

Install Hose and Nozzle

CAUTION: Make sure any hose and nozzle used are compatible with the chemical pumped.

If installing accessories such as meters or filters, do so now, following manufacturer's instructions.

After sealing threads, hand-tighten the hose into the outlet until snug. Hand-tighten nozzle to hose.

OPERATION

Read, understand, and follow all safety instructions given at the front of this manual.

Using fluids other than those for which the pump was designed could lead to serious personal injury and void the warranty.

If the pump was used last year, follow Beginning of Season procedures in the Maintenance Section.

Clean any spills from the system exterior as they occur, following chemical manufacturer's instructions.

Before Each Use

1. Keep pump exterior clean to help identify leaks. Before each use, inspect for leaks around seals or connections. If found, refer to the Troubleshooting Section.
2. Check for leaks under the pump housing. A small drain hole relieves any chemical which bypasses the motor shaft seal. (Figure 4) If **any** leakage is found here, replace the motor shaft seal using instructions in the Repair Section.

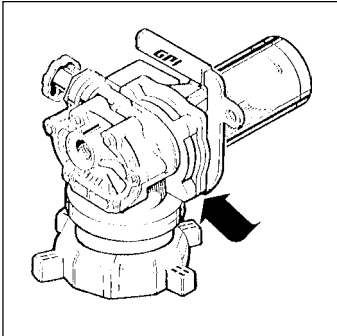

Figure 4

3. Make sure hoses are in good condition and connections are tight.
4. Make sure the work area is dry.

!!! WARNING !!!

Serious electrical shock can result from operating electrical equipment on wet ground.

5. Inspect wiring for corrosion or damage. Replace, as necessary.
6. Connect the pump to a 12-volt DC battery with the red wire attached to positive (+) and the black to negative (-).
7. Purge the system of air.

NOTE: The pump must be kept free of air to make sure chemical does not dry inside the pump. If drying occurs, clean before further use.

- a. Place the nozzle into the fill hole of the chemical tank. (Figure 5) Turn the pump ON.



Figure 5

- b. Open the nozzle and pump at full flow until the system is full of chemical.
- c. Close the nozzle and turn the pump OFF.

Recirculation

When using chemicals that tend to separate, you must recirculate to mix before dispensing. Follow the chemical manufacturer's recommendations for proper recirculation.

Automatic bypass is provided on pumps with 2-inch inlets. If your pump has an automatic bypass, disregard references to manual bypass and recirculation.

NOTE: Both automatic and manual bypass poppets will open automatically if internal pump pressure builds up.

If your pump has a manual bypass, recirculate chemical as follows:

1. Make sure the nozzle is closed.
2. Pull out the bypass knob and turn 1/4 turn counterclockwise so it rises about 1/2 inch. (Figure 6)

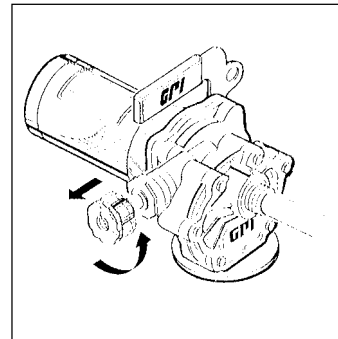

Figure 6

3. Turn the pump ON to recirculate.
4. Before dispensing, close the bypass poppet by turning clockwise and pushing in.

Dispense Chemical

The P-120H pump is intended for use with thin chemicals and the P-200H for medium/thick chemicals only. Some chemicals may become too thick to pump if outside temperature is less than 50° F (10° C).

1. Turn power ON.
2. Insert the nozzle into the receiving tank.
3. Open the nozzle. Always dispense at full flow.

CAUTION: Do not exceed the standard duty cycle of 30 minutes ON and 30 minutes OFF. Allow the pump to cool for 30 minutes. The colder or thicker the chemical, the shorter the duty cycle should be.

4. Dispense the desired amount.
5. Close the nozzle and turn the pump OFF.

MAINTENANCE

Read, understand, and follow all safety instructions given at the front of this manual.

Proper cleaning and maintenance is vital to prolong system life and promote trouble-free operation.

NOTE: Failure to follow recommended cleaning and storage procedures increases the chance of pump failure and may void the warranty.

Replace Fuse

1. Locate the fuse holder on the power cord.
2. To remove fuse, push the ends together and twist. (Figure 7) Replace the blown fuse.



Figure 7

Remove Pump from Tank

1. Disconnect pump from power.
2. Loosen the union ring or spin collar to release the inlet fitting.
3. Lift the pump from the bung adapter. (Figure 8) The gasket may stick inside the inlet fitting.



Figure 8

4. Place the nozzle in the tank. (Figure 9)



Figure 9

5. Connect pump to power and turn it on. Open the nozzle to remove chemicals from the system. Turn pump OFF and disconnect.
6. Remove the suction pipe, as necessary.
7. Clean chemical from bung adapter and tank. Cover the bung adapter.
8. If the system will not be used for more than two weeks, flush to prevent drying of chemicals in the pump.

Flushing

When the pump will not be in use for more than two weeks, it must be flushed to prevent internal drying of chemicals.

1. Remove and drain the pump using instructions above.
2. The 4-inch inlet seals automatically when removed from the bung. To hold it open, temporarily install a spare bung adapter or nipple on the pump. (Figure 10)



Figure 10

3. Place the pump inlet and nozzle in a container of water. (Figure 11)



Figure 11

4. Open the nozzle and turn the pump ON. Circulate water through the pump for 10 to 15 minutes. Open and close the nozzle several times to flush the bypass poppet.
5. Lift the pump from the water. Allow the pump to run briefly until only air passes through the system. Switch the pump OFF.

CAUTION: Do not run the pump any longer than necessary without flow. "Dry running" can cause overheating and pump damage.

6. Drain the hose and nozzle. Wipe entire system with a clean wet cloth.

Clean Pump

If chemicals dry inside the pump, remove the residue before further use.

1. Remove the pump from the tank and flush.
2. Disassemble the pump as outlined in the Repair Section. (Figure 12)



Figure 12

3. Thoroughly clean dried chemical from the interior of the pump. Take care not to scratch parts.

NOTE: Do not disassemble the manual bypass poppet assembly or the inlet fitting.

4. Wash the bypass poppet assembly in warm soapy water. Rotate the spring and plug on the manual bypass poppet assembly to make sure they move freely. (Figure 13)



Figure 13

5. Assemble the pump again.

End of Season

If the system will not be used for an extended time, flush and clean, as necessary. Prepare for storage as follows:

1. For pumps with a 4-inch inlet, open the automatic shutoff valve by installing a spare bung adapter on the pump.
2. Connect a short length of petroleum-compatible flushing hose to the pump.
3. Place the pump inlet and the hose end in a container of 100% antifreeze. (Figure 14)



Figure 14

4. Turn the pump ON. Circulate antifreeze through the pump for 1 to 2 minutes. Restrict the flow several times to allow antifreeze to enter the bypass poppet.
5. Lift the pump from the antifreeze. Allow the pump to run **briefly** until only air passes through the system. (Figure 15) Switch the pump OFF.



Figure 15

CAUTION: Do not run the pump any longer than necessary without flow. "Dry running" can cause overheating and pump damage.

6. Drain and remove the hose.
7. Wipe pump and power cord with a clean cloth.
8. Store in a dry location.

Beginning of Season

Prior to initial or seasonal pump use, check the following:

1. Drain antifreeze and flush system.
2. Install the pump.
3. Complete the steps given in Before Each Use.

REPAIR

Read, understand, and follow all safety instructions given at the front of this manual.

During repair, carefully inspect all parts for wear or damage and replace, as necessary. Check O-rings and seals for breakage, wear, and signs of deterioration, such as swelling. Before installing, coat O-rings, seals, and drive components with high temperature lithium grease.

Clean or Replace Strainer

1. Disconnect pump from power and flush.
2. Remove the coverplate and O-ring from the housing. (Figure 16)



Figure 16

3. Remove the inlet strainer.
4. Clean or replace the strainer. Install again.
5. Install the coverplate and O-ring. Torque screws to 25 to 35 in. lbs.

Clean or Replace Inlet Fitting

NOTE: Do not disassemble the inlet fitting.

1. Disconnect pump from power and flush.
2. Remove the inlet fitting from the pump housing. (Figures 17 and 18)



Figure 17



Figure 18

3. Clean or replace the inlet fitting. Install again. Torque screws to 25 to 35 in. lbs.

NOTE: Ensure proper seating of the gasket between the union ring and the pump housing.

Convert an Inlet Fitting

Inlet fittings may be converted from 2-inch to 4-inch or 4-inch to 2-inch. Using replacement instructions above, simply remove one fitting and install the other.

Clean or Replace Bypass Poppet

1. Disconnect pump from power and flush.
2. Remove the bypass poppet plug. (Figure 19)



Figure 19

3. Remove the bypass poppet. Gently rock it back and forth as necessary to remove.
4. Wipe the cavity clean and wash the bypass poppet in warm soapy water.

NOTE: Do not disassemble the manual bypass poppet assembly. Rotate the spring and plug on the assembly to make sure they move freely.

5. Examine all components and replace as necessary.
6. To replace the poppet O-ring:
 - a. Carefully remove the O-ring using a small screwdriver or similar tool.
 - b. Coat the O-ring with grease and seat on the poppet head.
7. Assemble by placing the bypass poppet assembly in the cavity. Tighten the plug firmly.

Replace the Motor, Switch or Power Cord

To replace the motor:

1. Disconnect pump from power and flush.
2. Remove the screws holding the motor and handle to housing.
3. Lift the motor from the housing and drive shaft. (Figure 20)



Figure 20

4. As appropriate for your pump:
 - a. Remove the motor shaft adapter from the drive shaft or,
 - b. Remove the screws on the planetary gear module and slip it from the drive shaft. (Figure 21)



Figure 21

5. If replacing the motor only, remove the power cord using instructions below.
6. Assemble by reversing steps above. Make sure the motor is properly seated against the motor adapter seal. Torque screws to 75 to 100 in. lbs.

To replace the switch:

1. Disconnect pump from power and flush.
2. Remove the switch coverplate on the side of the motor.
3. Press in on the sides of the switch. Push the switch from the switch box.

NOTE: Before disconnecting wires, note their positions on the switch. Connect to the new switch in the same positions.

4. Disconnect the terminal wires from the back of the old switch. (Figure 22)

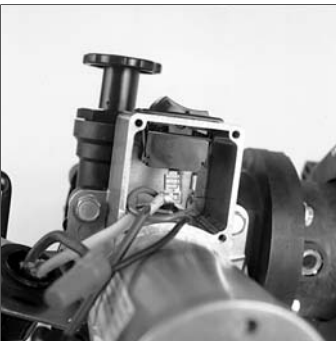

Figure 22

5. Install the new switch by reversing steps above. Carefully position wires in switch box before replacing coverplate.
6. Install coverplate and tighten screws until snug. Do not overtighten.

To replace the power cord:

1. Disconnect pump from power and flush.
2. Remove the switch coverplate on the side of the motor.
3. Remove electrical tape and unscrew the wire nut. Remove wire from terminal on back of the switch. (Figure 23)



Figure 23

4. Remove the old power cord.
5. Install new power cord by reversing steps above.
6. Secure wire nut with two wraps of electrical tape.
7. Install coverplate and tighten screws until snug. Do not overtighten.

Replace the Drive Shaft or Motor Shaft Seal

To remove the drive shaft and motor shaft seal:

1. Disconnect pump from power and flush.
2. Remove the motor as described above.
3. Carefully slide the drive shaft from the motor and the housing. Note the position of the motor shaft washer.
4. Carefully pry the motor shaft seal from the housing with a flat-bladed screwdriver.
5. Inspect the drive shaft, motor shaft washer, motor shaft seal, and bearings for wear. Replace, as necessary.

To install the drive shaft and motor shaft seal:

1. Press the new motor shaft seal into the housing.
2. Position the motor shaft washer on the seal. Slide the notched end of the drive shaft into place in the housing.
3. As appropriate for your pump, align the drive shaft with the motor adapter or the planetary gear module. When properly aligned, the drive shaft will slip into place with the motor against the housing.
4. During assembly, make sure the motor is properly seated against the motor adapter seal and the housing.
5. Replace the screws fastening the motor and handle to the housing. Use the two longer screws to secure the handle. Torque to 75 to 100 in. lbs.

Replace Gears, Wearplates or Drive Key

NOTE: If your pump does not contain wearplates, ignore wearplate instructions below.

To remove gears, wearplates and drive key:

1. Disconnect pump from power and flush thoroughly.
2. Remove the coverplate and O-ring from the housing.
3. As appropriate for your pump, remove the drive key, wearplates, and gears from the housing. (Figure 24)



Figure 24

To assemble gears, wearplates and drive key:

1. Position a wearplate in the housing with the rounded edge of the wearplate facing the gears.
2. Place a gear over the drive shaft.
3. Align the slotted drive shaft end with the gear.
4. Place the other gear in the housing. Turn the gears to make sure they do not bind. Carefully place the key in the slot.
5. Position the other wearplate with the rounded edge facing the gears. Make sure it is flush with the housing.
6. Replace the O-ring and coverplate. Torque screws to 25 to 35 in. lbs.

4. Inspect gears, wearplates, and key for wear or damage. Replace, as necessary. Clean cavity.

TROUBLESHOOTING

SYMPTOM	PROBABLE CAUSE	CORRECTIVE ACTION
A. MOTOR DOES NOT RUN	<ol style="list-style-type: none"> 1. Fuse blown 2. Switch defective 3. Motor burned out 	<p>Inspect fuse. If blown, replace.</p> <p>Remove switch coverplate and inspect switch. Replace, if necessary.</p> <p>Remove motor from pump and test by connecting to 12-volt DC power supply. Replace, if necessary.</p>
B. MOTOR RUNS BUT DOES NOT PUMP CHEMICAL	<ol style="list-style-type: none"> 1. System air leak 2. Drive key broken 3. Strainer clogged 4. Gear coverplate O-ring worn 5. Bypass poppet stuck 6. Manual bypass poppet in open position 7. Suction pipe clogged, damaged or missing 8. Gear drive shaft broken 9. 4-in. bung adapter spring clogged 10. Gear wear 	<p>Make sure all fittings and connections are tight. Inspect suction pipe, bung adapter, and pump inlet seals for leaks or damage.</p> <p>Replace key.</p> <p>Remove coverplate. Clean strainer. Install again.</p> <p>Remove coverplate. Inspect O-ring and replace if worn or damaged.</p> <p>Remove poppet and clean. Install again.</p> <p>Close poppet by turning clockwise and pushing in.</p> <p>Remove pump and bung adapter. Inspect suction pipe and clean or replace, as necessary.</p> <p>Remove coverplate, wearplates (as appropriate), gears, and motor. Remove and inspect drive shaft. Replace, if necessary.</p> <p>Remove pump and bung adapter. Clean spring and install again.</p> <p>Remove the coverplate and inspect wearplates (as appropriate), gears, and drive key. Gears must turn freely with the drive key removed. Replace any worn or damaged parts.</p>
C. LOW FLOW RATE	<ol style="list-style-type: none"> 1. Low voltage or poor connections 2. Strainer partially clogged 3. Suction pipe clogged or damaged 4. Bypass poppet stuck 5. Gear wear 6. Discharge hose too long 7. Power cord too long 8. Chemical too thick for pump 	<p>Check for adequate battery voltage and good clamp connections.</p> <p>Remove coverplate. Clean strainer. Install again.</p> <p>Remove pump from tank. Inspect suction pipe and clean or replace, as necessary.</p> <p>Remove poppet and clean. Install again.</p> <p>Remove the coverplate and inspect wearplates (as appropriate), gears, and drive key. Gears must turn freely with the drive key removed. Replace any worn or damaged parts.</p> <p>Long hoses reduce flow rate. Shorten hose.</p> <p>Long cords reduce flow rate. Shorten cord.</p> <p>Use only chemical viscosity appropriate for pump. Allow chemical to warm if operating at low temperatures.</p>
D. RAPID OVERHEATING OF MOTOR	<ol style="list-style-type: none"> 1. Duty cycle too long 2. Chemical too thick for pump 3. Strainer clogged 	<p>Do not exceed the standard duty cycle of 30 minutes ON and 30 minutes OFF. Allow the pump to cool for 30 minutes.</p> <p>Use only chemical viscosity appropriate for pump. Allow chemical to warm if operating at low temperatures.</p> <p>Remove coverplate. Clean strainer. Install again.</p>

ILLUSTRATED PARTS LIST

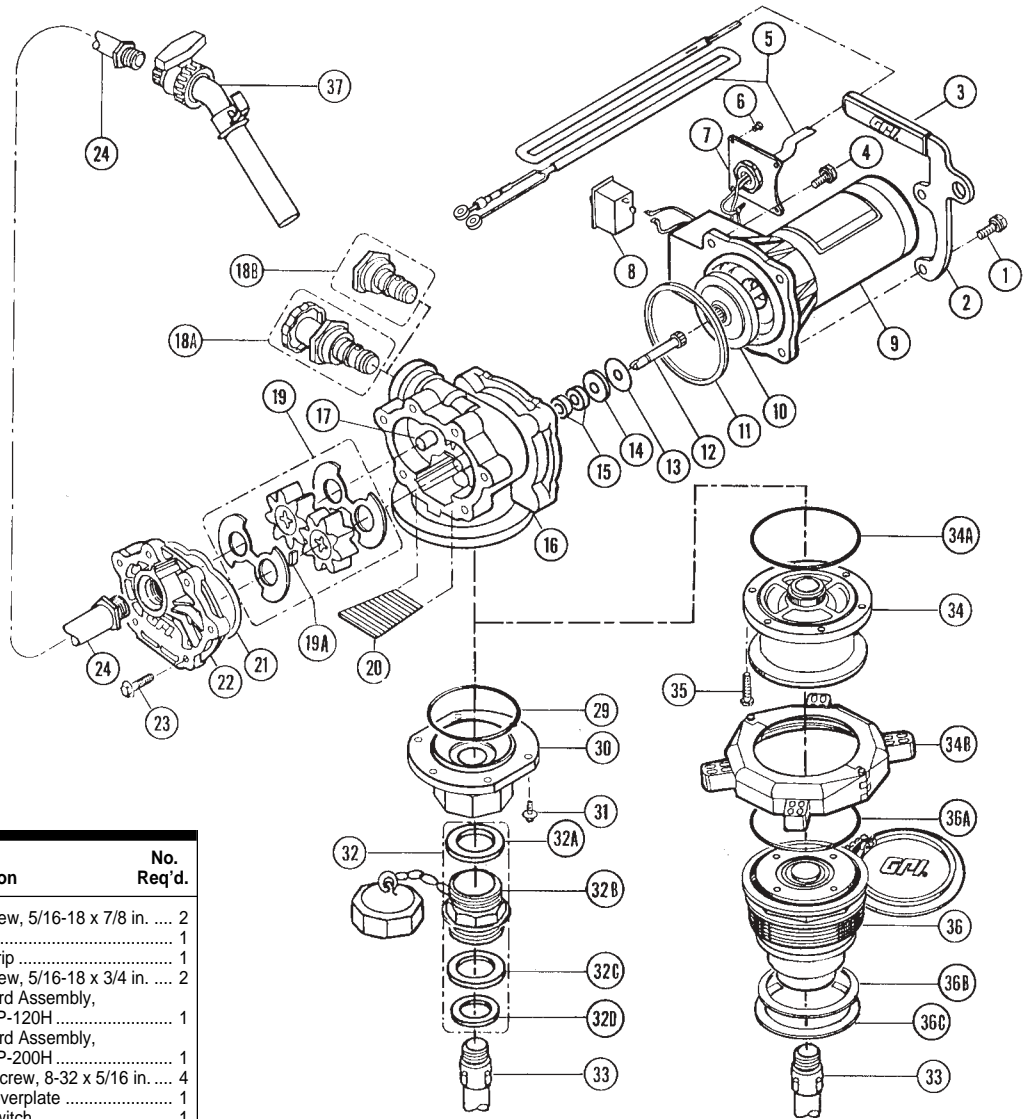

Item No.	Part No.	Description	No. Req'd.
1	904003-92	Sems Screw, 5/16-18 x 7/8 in.	2
2	118021-1	Handle	1
3	118023-1	Handle Grip	1
4	904002-24	Sems Screw, 5/16-18 x 3/4 in.	2
5	115016-11	Power Cord Assembly, 15 ft., P-120H	1
	110215-9	Power Cord Assembly, 15 ft., P-200H	1
6	904001-99	Pan HD Screw, 8-32 x 5/16 in.	4
7	119077-2	Switch Coverplate	1
8	902002-91	Rocker Switch	1
9	119002-17	Motor Assembly 12V DC (P-120H)	1
	119002-18	Motor Assembly 12V DC (P-200H)	1
10	906001-67	Planetary Gear Module, P-200H	1
	904003-50	Sems Screw, 8-32 x 11/16 in., P-200H, not shown	4
	118016-1	Shaft Adapter, P-120H, not shown	1
11	901001-91	Motor Adapter Seal	1
12	110204-2	Drive Shaft Assembly	1
13	904003-70	Motor Shaft Washer	1
14	110078-8	Motor Shaft Seal	1
15	118020-1	Bearing	2
16	118006-1	Pump Housing	1
17	110018-2	Gear Shaft Support	2
18-A	118507-1	Bypass Poppet Assembly Kit, P-120H, 4-inch	1
	118508-1	Bypass Poppet Assembly Kit, P-200H, 4-inch	1

Item No.	Part No.	Description	No. Req'd.
18-B	118508-2	Bypass Poppet Assembly Kit, P-120H & P-200H, 2-inch	1
19	118501-1	Gear Kit, P-120H	1
	118502-1	Gear Kit, P-200H	1
19-A	110017-2	Key	1
20	110063-2	Inlet Strainer	1
21	118017-1	Coverplate O-ring	1
22	118007-1	Coverplate	1
23	904003-49	Sems Screw (1/4-20 x 1 in.)	6
24	110189-2	EPDM Hose (1 in. x 12 ft.) (optional)	1
29	901002-38	Inlet O-ring	1
30	115018-5	Lower Cover Assembly (2 in.)	1
31	904003-91	Sems Screw (1/4-20 x 3/4 in.)	2
32	115090-5	Bung Adapter Assembly	1

Item No.	Part No.	Description	No. Req'd.
32-A	114029-2	EPDM Gasket	1
32-B	115088-5	Bung Adapter, 2 in.	1
32-C	115085-1	Teflon® Gasket	1
32-D	115084-1	EPDM Gasket	1
33	110100-2	Adjustable Suction Pipe (optional)	1
34	118100-1	Inlet Module Assembly, 4 in.	1
34-A	901002-38	Inlet O-ring	1
34-B	115542-3	Spin Collar Kit, with knobs	1
35	904003-91	Sems Screw (1/4-20 x 3/4 in.)	6
36	115500-4	Bung Adapter Assembly, 4 in.	1
36-A	901002-11	O-ring	1
36-B	115547-1	Teflon® Gasket	1
36-C	115509-2	EPDM Gasket	1
37	110107-2	Discharge Nozzle (optional)	1

Kits and Accessories

- 118501-1 P-120H Gear Kit includes a key and two gears.
- 118502-1 P-200H Gear Kit includes a key, two gears, and two wearplates.
- 118503-1 Overhaul Kit includes a coverplate O-ring, motor shaft seal, motor adapter seal, inlet O-ring, camplug O-ring, bypass poppet O-ring, plunger O-ring, key, and two gears.
- 118505-1 Drive Shaft Kit includes two bearings, motor shaft seal, motor shaft washer, drive shaft assembly, and motor adapter seal.
- 118506-1 Seal Kit includes the coverplate O-ring, motor shaft seal, motor adapter seal, inlet O-ring, camplug O-ring, poppet O-ring, and plunger O-ring.
- 118507-1 P-120H Bypass Poppet Assembly Kit for 4-inch inlet includes manual and automatic bypass features.

- 118508-1 P-200H Bypass Poppet Assembly Kit for 4-inch inlet includes manual and automatic bypass features.
- 118508-2 P-120H and P-200H Bypass Poppet Assembly Kit for 2-inch inlet includes automatic bypass feature only.
- 118509-1 4-inch Inlet Fitting to convert 2-inch pump to 4-inch.
- 118509-3 2-inch Inlet Fitting to convert 4-inch pump to 2-inch.
- 111502-2 Herbicide Hose and Nozzle Kit includes 1 in. x 12 ft. (3.7m) EPDM hose, ball valve nozzle, and adjustable suction pipe.

P-120H SPECIFICATIONS

Applications

Fluids: Thin (0 to 10 centipoise viscosity) chemicals.
Operating Environment: Outdoor, operating temperature range of -20 to +120°F (-30 to +50°C). Designed for mounting on above ground storage tanks.

Pump Housing

Lightweight, durable, molded plastic housing for chemical corrosion resistance. Convenient union ring or spin collar for easy installation.

Performance

Pump Rate: Up to 12 GPM (45 LPM). Rate will vary with viscosity and temperature.
Duty Cycle: 30 min. ON, 30 min. OFF. Duty cycle will vary with viscosity and temperature.

Electrical Specifications

Input: 12-volt DC
Current: 12-15 amps
Cord: 14 gauge, 15 ft. (4.6m)
Fuse: 20 amps AGC

Mechanical Connections

Bung: 2 or 4 inch
Inlet: 1 inch
Outlet: 1 inch

Recommended Accessories

Standard EPDM 1 in. x 12 ft. (3.7m) discharge hose.
Standard 1 in. ball valve nozzle.

Weight

Shipping: 15 lbs. (6.8kg)

P-200H SPECIFICATIONS

Applications

Fluids: Medium/thick (10 to 450 centipoise viscosity) chemicals.
Operating Environment: Outdoor, operating temperature range of -20 to +120°F (-30 to +50°C). Designed for mounting on above ground storage tanks.

Pump Housing

Lightweight, durable, molded plastic housing for chemical corrosion resistance. Convenient union ring or spin collar for easy installation.

Performance

Pump Rate: Up to 8 GPM (30 LPM). Rate will vary with viscosity and temperature.
Duty Cycle: 30 min. ON, 30 min. OFF. Duty cycle will vary with viscosity and temperature.

Electrical Specifications

Input: 12-volt DC
Current: 15-24 amps
Cord: 10 gauge, 15 ft. (4.6m)
Fuse: 25 amps AGC

Mechanical Connections

Bung: 2 or 4 inch
Inlet: 1 inch
Outlet: 1 inch

Recommended Accessories

Standard EPDM 1 in. x 12 ft. (3.7m) discharge hose.
Standard 1 in. ball valve nozzle.

Weight

Shipping: 15 lbs. (6.8kg)

PARTS AND SERVICE

For warranty consideration, parts or other service information, please contact your local distributor. If you need further assistance, contact the GPI Customer Service Department in Wichita, Kansas, during normal business hours.

A toll free number is provided for your convenience.

1-800-835-0113

To obtain prompt, efficient service, always be prepared with the following information:

- The model number of your pump
- The serial number or manufacturing date code of your pump
- Part descriptions and numbers

Part information can be obtained from the Illustrated Parts List.

For warranty work, always be prepared with your original sales slip or other evidence of purchase date.

Please contact GPI before returning any parts. It may be possible to diagnose the trouble and identify needed parts in a telephone call or letter. GPI can also inform you of any special requirements you will need to follow for transportation and handling of chemical equipment.

NOTE: Do not return pumps without specific authority from the Customer Service Department. Due to strict regulations governing transportation, handling, and disposal of chemicals, pumps will not be accepted for rework unless they are completely free of chemical.

Limited Warranty Policy

Great Plains Industries, Inc. 5252 E. 36th Street North, Wichita, KS USA 67220-3205, hereby provides a limited warranty against defects in material and workmanship on all products manufactured by Great Plains Industries, Inc. This product includes a 1 year warranty. Manufacturer's sole obligation under the foregoing warranties will be limited to either, at Manufacturer's option, replacing or repairing defective Goods (subject to limitations hereinafter provided) or refunding the purchase price for such Goods theretofore paid by the Buyer, and Buyer's exclusive remedy for breach of any such warranties will be enforcement of such obligations of Manufacturer. The warranty shall extend to the purchaser of this product and to any person to whom such product is transferred during the warranty period.

The warranty period shall begin on the date of manufacture or on the date of purchase with an original sales receipt. This warranty shall not apply if:

- A. the product has been altered or modified outside the warrantor's duly appointed representative;
- B. the product has been subjected to neglect, misuse, abuse or damage or has been installed or operated other than in accordance with the manufacturer's operating instructions.

To make a claim against this warranty, contact the GPI Customer Service Department at 316-686-7361 or 800-835-0113. Or by mail at:
Great Plains Industries, Inc.
5252 E. 36th St. North
Wichita, KS, USA 67220-3205

The company shall, notify the customer to either send the product, transportation prepaid, to the company at its office in Wichita, Kansas, or to a duly authorized service center. The company shall perform all obligations imposed on it by the terms of this warranty within 60 days of receipt of the defective product.

GREAT PLAINS INDUSTRIES, INC., EXCLUDES LIABILITY UNDER THIS WARRANTY FOR DIRECT, INDIRECT, INCIDENTAL AND CONSEQUENTIAL DAMAGES INCURRED IN THE USE OR LOSS OF USE OF THE PRODUCT WARRANTED HEREUNDER.

The company herewith expressly disclaims any warranty of merchantability or fitness for any particular purpose other than for which it was designed.

This warranty gives you specific rights and you may also have other rights which vary from U.S. state to U.S. state.

Note: In compliance with MAGNUSON MOSS CONSUMER WARRANTY ACT – Part 702 (governs the resale availability of the warranty terms).



GPI is a registered trademark of Great Plains Industries, Inc.
Patent No. D339,810

© 2005 by GREAT PLAINS INDUSTRIES, INC., Wichita, KS
Printed in U.S.A.

02/05



5252 East 36th Street North
Wichita, KS USA 67220-3205
TEL: 316-686-7361
FAX: 316-686-6746

GREAT PLAINS INDUSTRIES, INC.

"A Great Plains Ventures Subsidiary"

www.gpi.net

1-800-835-0113

Rev. A 921751-01